



Series  
DSX

CRIMP REMOVABLE  
SIZE 22 - 22 SOCKET CONTACT  
/

Issue:  
06.29.01

Page  
1 / 1

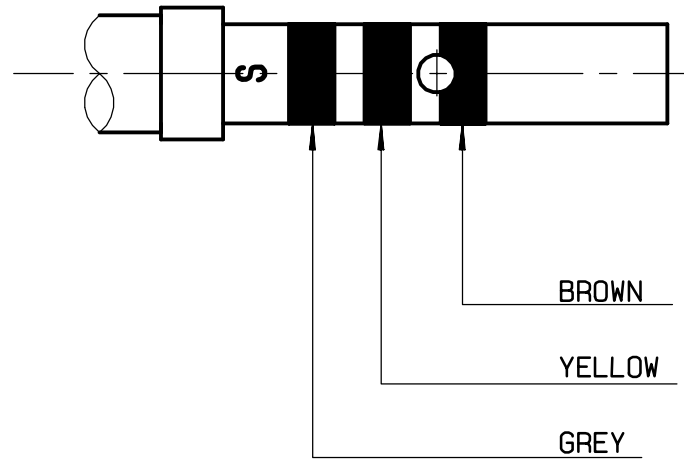
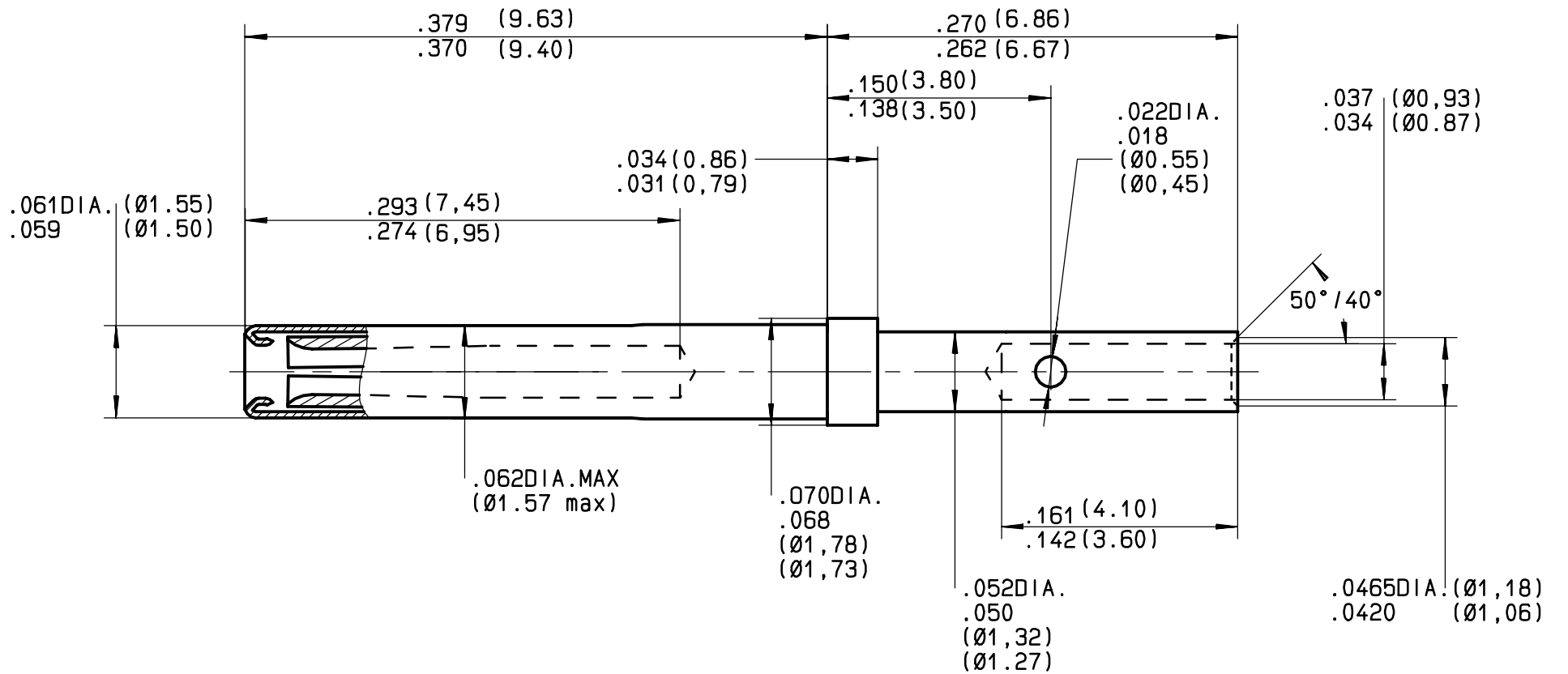

WIRES ACCOMODATED : AWG 22 - 24 AND 26  
INSULATION DIAMETER : .054 (1,40) MAX  
STRIP LENGTH : .138 (3,50)

**TOOLING**

CRIMPING TOOL : M 22520/2-01  
SELECTOR POSITION : 4 FOR AWG22  
3 FOR AWG24 AND 26

POSITIONER : M 22520/2-23

**MATERIAL AND FINISHES**

BODY CONTACT : NICKEL COPPER HEAT TREATED HARDNESS < 200 HV  
BARREL ANNEALED HARDNESS 60\_80 HV

PLATING : NICKEL .00005 INCH THICK PER QQ\_N\_290  
GOLD .00005 INCH THICK PER MIL\_G\_45204 TYPE I OR II GRADE C OR D

PROTECTIVE SLEEVE : PASSIVATED STAINLESS STEEL AISI 305

This information is given as an indication. In the continual goal to improve our products, we reserve the right to make any modifications judged necessary.

4112-9610

CREATION				
PEN: /				
NOM: FALETTI				
DATE: 29.05.88	06/29/01	DRAWING ENGLISH CREATING	FISCHER	GOMBERT
APPR.: /	Issue	Revisions	Name	Approved